

4

3

2

1

THIS DRAWING IS UNPUBLISHED. RELEASED FOR PUBLICATION, 19 .

© COPYRIGHT 19 BY AMP INCORPORATED. ALL RIGHTS RESERVED.

| LOC | DIST | REVISIONS   |                                 |           |      |
|-----|------|-------------|---------------------------------|-----------|------|
| P   | LTR  | DESCRIPTION | DATE                            | DWN       | APVD |
| FT  | 60   | G           | REDRAWN & REV PER EC 0320-74-97 | 15 APR 97 | -    |

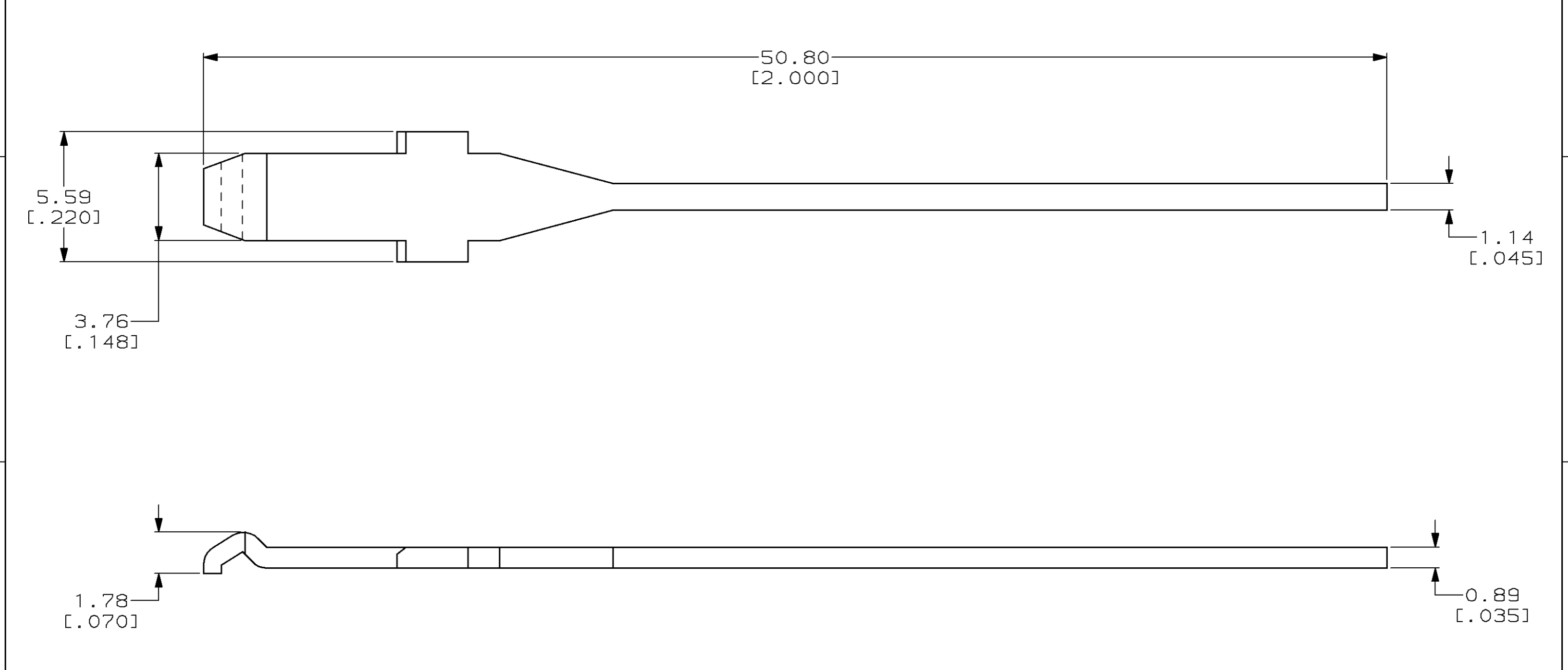

|        |             |
|--------|-------------|
| △1     | 54326-2     |
| △2     | 54326-1     |
| FINISH | PART NUMBER |

- △1 5.08µm [.000200] MIN SILVER.
- △2 0.76µm [.000030] MIN GOLD OVER  
1.27µm [.000050] MIN NICKEL.

|  |                     |                              |                       |  |       |    |       |              |       |    |       |    |        |    |                           |
|--|---------------------|------------------------------|-----------------------|--|-------|----|-------|--------------|-------|----|-------|----|--------|----|---------------------------|
| THIS DRAWING IS A CONTROLLED DOCUMENT.   |                     | DWN<br>M. BINNER             | 15 APR 97             | <b>AMP</b> AMP Incorporated<br>Harrisburg, PA 17105-3608 |       |    |       |              |       |    |       |    |        |    |                           |
| DIMENSIONS:<br>mm [INCHES]   |                     | CHK<br>R. STONE              | 24 APR 97             |  |       |    |       |              |       |    |       |    |        |    |                           |
| TOLERANCES UNLESS OTHERWISE SPECIFIED:   |                     | APVD<br>M. MCALONIS          | 22 MAY 97             |  |       |    |       |              |       |    |       |    |        |    |                           |
| <table border="1"> <tr><td>0 PLC</td><td>±-</td></tr> <tr><td>1 PLC</td><td>±-</td></tr> <tr><td>2 PLC</td><td>±0.51 [.020]</td></tr> <tr><td>3 PLC</td><td>±-</td></tr> <tr><td>4 PLC</td><td>±-</td></tr> <tr><td>ANGLES</td><td>±-</td></tr> </table> |                     | 0 PLC                        | ±-                    |  | 1 PLC | ±- | 2 PLC | ±0.51 [.020] | 3 PLC | ±- | 4 PLC | ±- | ANGLES | ±- | PRODUCT SPEC<br>108-11026 |
| 0 PLC  | ±-                  |                              |                       |  |       |    |       |              |       |    |       |    |        |    |                           |
| 1 PLC  | ±-                  |                              |                       |  |       |    |       |              |       |    |       |    |        |    |                           |
| 2 PLC  | ±0.51 [.020]        |                              |                       |  |       |    |       |              |       |    |       |    |        |    |                           |
| 3 PLC  | ±-                  |                              |                       |  |       |    |       |              |       |    |       |    |        |    |                           |
| 4 PLC  | ±-                  |                              |                       |  |       |    |       |              |       |    |       |    |        |    |                           |
| ANGLES   | ±-                  |                              |                       |  |       |    |       |              |       |    |       |    |        |    |                           |
| MATERIAL<br>COPPER ALLOY   | FINISH<br>SEE TABLE | APPLICATION SPEC<br>114-6032 | WEIGHT<br>-           | SIZE<br>A3   |       |    |       |              |       |    |       |    |        |    |                           |
| CUSTOMER DRAWING   |                     |                              | SCALE<br>6:1          | CAGE CODE<br>00779                                       |       |    |       |              |       |    |       |    |        |    |                           |
|  |                     |                              | DRAWING NO<br>C-54326 | RESTRICTED TO<br>-                                       |       |    |       |              |       |    |       |    |        |    |                           |
|  |                     |                              | SHEET<br>1 OF 1       | REV<br>G   |       |    |       |              |       |    |       |    |        |    |                           |